

THIS DOCUMENT IS THE PROPERTY OF APEM COMPONENTS AND SHALL NOT BE COPIED, REPRODUCED, DISCLOSED OR USED AS THE BASIS FOR MANUFACTURING OR SALE WITHOUT PERMISSION OF A DULY AUTHORIZED REPRESENTATIVE OF APEM COMPONENTS INC.

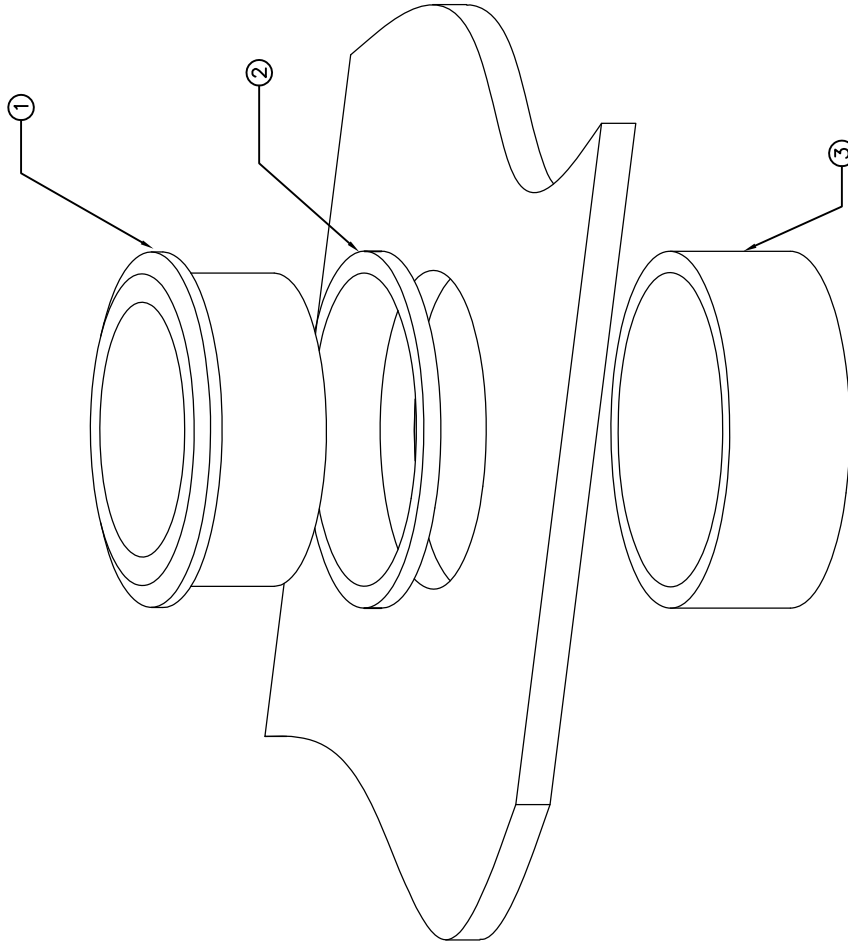

HP** COLOR:

- 00= CLEAR ANODIZED
- 02= BLACK ANODIZED
- 03= GREEN ANODIZED
- 06= RED ANODIZED

| DATE | SYM | REVISION RECORD | DWN. | CK. |
|------|-----|-----------------|------|-----|
| 3/09 | B | ECO# 833 | CD | PD |
| | | | | |
| | | | | |

| NUMBER QTY. | DESCRIPTION | PART NUMBER |
|-------------|------------------------|-------------|
| 1 | RECESSED SWITCH BEZEL | E0139P1 |
| 2 | SEALING GASKET | 26--0036 |
| 3 | RECESSED SWITCH COLLAR | E0139P2 |

| | | |
|---|---------------------------|------------------------|
| <small>63 Neck Rd. Powell, MA 01835 Phone: 978-372-3534 Fax: 978-372-3534</small> | DRN.: | CJD |
| | CRK.: | PJD |
| DESIGNATES CRITICAL DIMENSION | | |
| TOLERANCES (EXCEPT AS NOTED) | SHEET | SCALE |
| .XX=±.02[0.5] | 1 OF 2 | B 3:1 |
| .XXX=±.008[0.20] | | |
| .XXXX=±.0008[0.02] | | |
| ANGLE = ±0.5° | | |
| DO NOT SCALE DRAWING | | |
| | TITLE | THIRD ANGLE PROJECTION |
| | RECESSED PUSHBUTTON BEZEL | |

| | | | | | |
|------|---------|-------------|------|-----|---|
| DATE | 2/17/09 | DRAWING NO. | HP** | REV | B |
|------|---------|-------------|------|-----|---|

THIS DOCUMENT IS THE PROPERTY OF APEM COMPONENTS AND SHALL NOT BE COPIED, REPRODUCED, DISCLOSED OR USED AS THE BASIS FOR MANUFACTURING OR SALE WITHOUT PERMISSION OF A DULY AUTHORIZED REPRESENTATIVE OF APEM COMPONENTS INC.

| DATE | SYM | REVISION RECORD | DWN. | CK. |
|------|-----|-----------------|------|-----|
| | | | | |
| | | | | |
| | | | | |

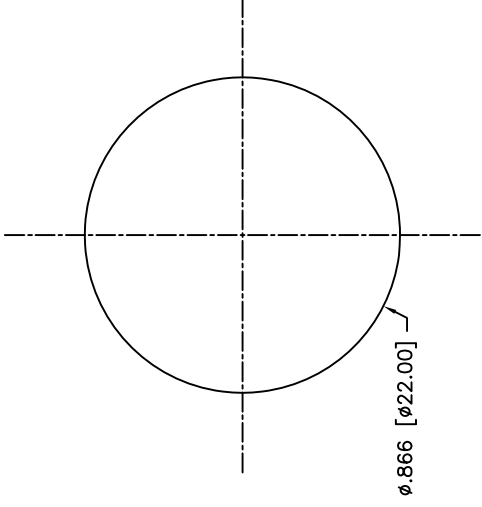
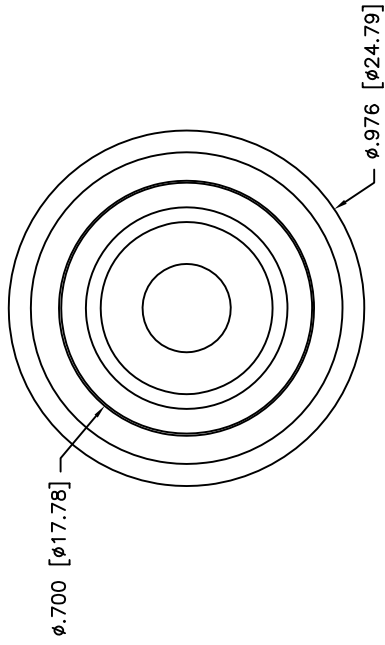

RECOMMENDED PANEL CUT-OUT

NOTE:
MATERIAL: MACHINED ALUMINIUM

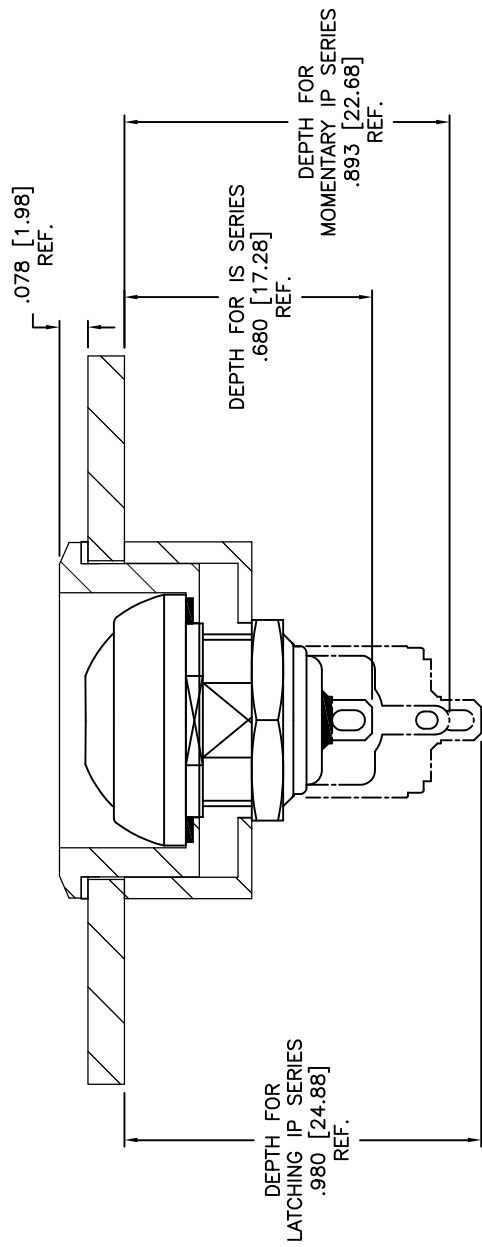

| | | | | | | |
|--|----------------------|--------------|------------------|-----------|------------------------|--|
| D.A. INSPECT DESIGNATES CRITICAL DIMENSION | INCH (MM) | SHEET 2 OF 2 | SIZE B | SCALE 3:1 | THIRD ANGLE PROJECTION | DRN. CJD |
| | | | | | | 63 Neck Rd. Haverhill, MA 01835 Tel: 978-372-3534 Fax: 978-372-3534 |
| TOLERANCES (EXCEPT AS NOTED) .XX = ±0.02(0.5) .XXX = ±0.008(0.20) .XXXX = ±0.0008(0.02) ANGLE = ±0.5° | DO NOT SCALE DRAWING | DATE 2/17/09 | DRAWING NO. HP** | REV B | 8 | |

TITLE RECESSED PUSHBUTTON BEZEL